



CT50/CT60 Vehicle Dock Series

Model CT50-MB
For CT50 and CT60 Mobile Computers

Quick Start Guide

Out of the Box

Make sure that your shipping box contains these items:

- Vehicle Dock
- Power cable (SKU/kit dependent)
- Product documentation

If any of these items are missing or appear damaged, contact your Customer Account Representative. Keep the original packaging in the event that you need to return the Vehicle Dock for service or if you want to store the charger while not in use.

Caution: We recommend the use of Honeywell accessories and power adapters. Use of any non-Honeywell accessories or power adapters may cause damage not covered by the warranty.

Mise en garde: Il est recommandé d'utiliser les périphériques, les cordons d'alimentation et les adaptateurs secteur conçus par Honeywell. L'utilisation de tout périphérique, cordon d'alimentation ou adaptateur secteur d'une autre marque est susceptible de provoquer des dommages non couverts par la garantie.

Front Features

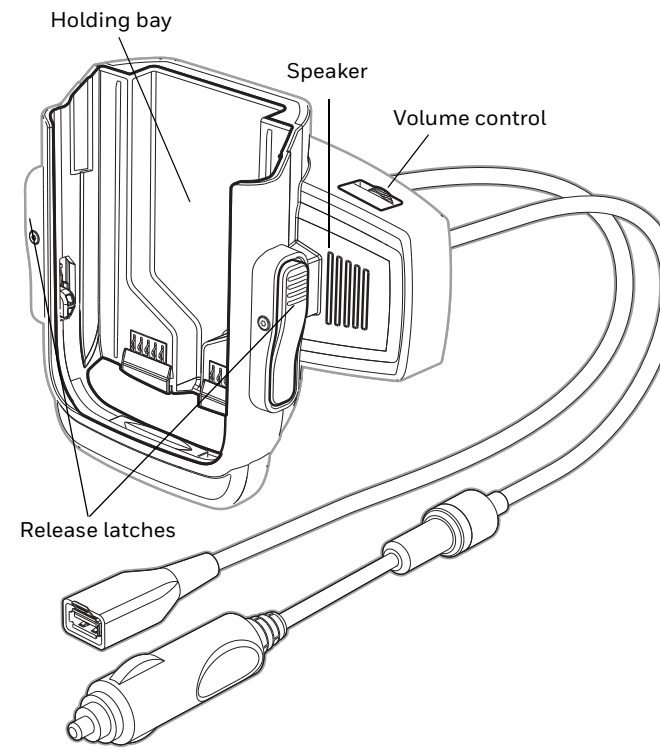

Connect Power

The vehicle that you connect the Vehicle Dock to should supply 2 A to the device. The operating temperature is -20 °C to 50 °C (-4 °F to 122 °F).

1. Connect the power cable adapter to a fused 12V power source on the vehicle.
 - When using the power adapter cable (shown in the image below), insert the adapter into the power socket.
 - When connecting to a vehicle fuse block using vehicle power connection kit 226-109-003 or 226-109-004 (sold separately), a qualified technician should perform the installation.

Note: If you require charging capabilities while the vehicle is turned off, connect the vehicle dock to an unswitched 12V source.

2. Screw the 3-pin connector on the vehicle dock power cable into the connector on the power cable adapter (SKU/kit dependent).
3. (Optional) Connect a secondary device (e.g., laptop, scanner, printer) to the USB communication cable on the vehicle dock. The USB cable can be mounted to a panel/bulkhead if desired. It can be tied out of the way if it is not used.

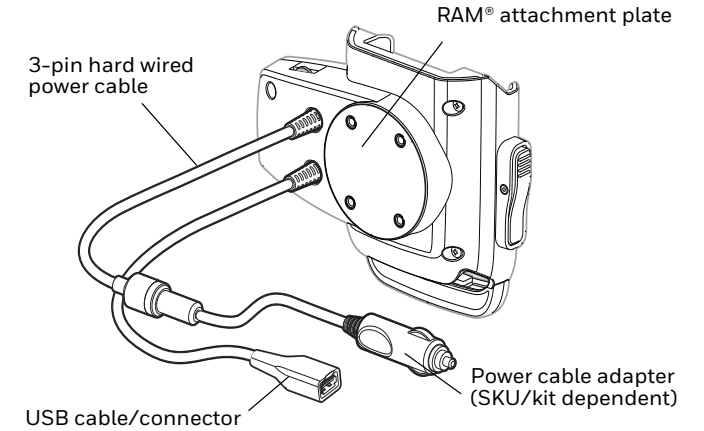

CT50-VD-MULT-QS Rev D
05/21

Charge the Device

Caution: Make sure that all components are dry prior to using the computers and batteries with accessories. Using wet components may cause damage not covered by the warranty.

Mise en garde : Assurez-vous que tous les composants sont secs avant de connecter les terminaux/batteries à des périphériques. L'insertion de composants humides risque de provoquer des dommages non couverts par la garantie.

- Insert the device with battery installed into the vehicle dock until the latches click.

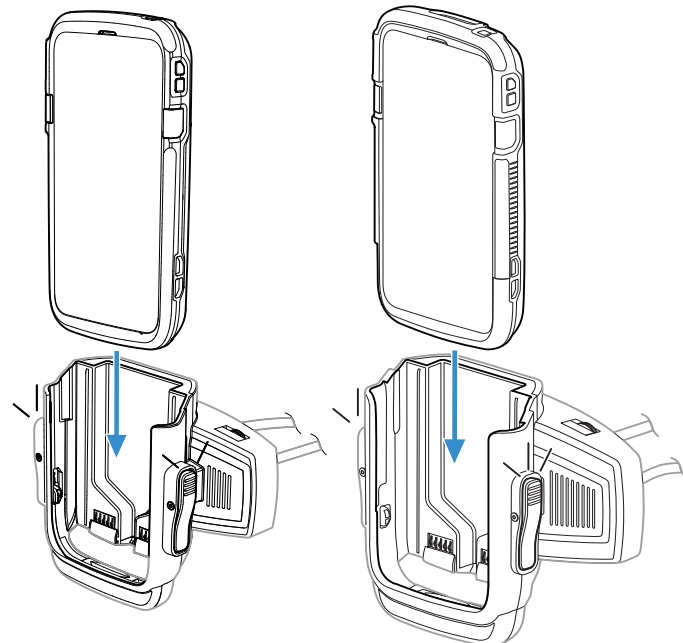

About the Volume Control

The vehicle dock has a built in volume control to enable you to hear the device in noisy environments.

- Rotate the volume control counter-clockwise to raise the volume.
- Rotate the volume control clockwise to lower the volume.

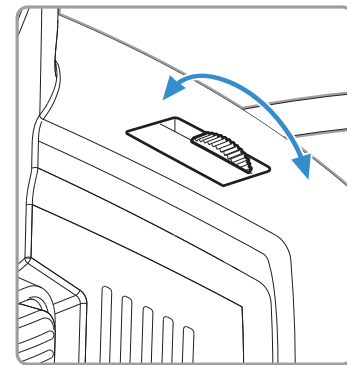

Mount the Vehicle Dock

You can mount the vehicle dock to your vehicle with a RAM mount.

Mounting hardware required:

- RAM mount
- Appropriate screws and nuts.

Agency Information

 UL and C-UL Statement UL and C-UL listed: UL 60950-1, Second Edition and CSA C22.2 No.60950-1-07, Second Edition.	 Norme UL et C-UL Homologué UL et C-UL : UL 60950-1, seconde édition et CSA C22.2 No.60950-1-07, seconde édition.
 RCM Mark Complies with ACMA regulatory arrangements.	 Customs Union Approval
 Mexico Conforms to NOM-019 Cumple con NOM-019 Está em conformidade com a NOM-	 NVCE
 이기기는가정용(居民)전자파적합기기로서주요가정에서 사용하는것을목적으로하며,모든지역에서사용할수있습니다.	

USA

FCC Part 15 Subpart B Class B

This device complies with part 15 of the FCC Rules. Operation is subject to the following two conditions:

1. This device may not cause harmful interference.
2. This device must accept any interference received, including interference that may cause undesired operation.

This equipment has been tested and found to comply with the limits for a Class B digital device pursuant to part 15 of the FCC Rules. These limits are designed to provide reasonable protection against harmful interference in a residential installation. This equipment generates, uses, and can radiate radio frequency energy and, if not installed and used in accordance with the instructions, may cause harmful interference to radio communications. However, there is no guarantee that interference will not occur in a particular installation. If this equipment does cause harmful interference to radio or television

reception, which can be determined by turning the equipment off and on, the user is encouraged to try to correct the interference by one or more of the following measures:

- Reorient or relocate the receiving antenna.
- Increase the separation between the equipment and receiver.
- Connect the equipment into an outlet on a circuit different from that to which the receiver is connected.
- Consult the dealer or an experienced radio or television technician for help.

If necessary, the user should consult the dealer or an experienced radio/television technician for additional suggestions. The user may find the following booklet helpful: "Something About Interference." This is available at FCC local regional offices. Honeywell is not responsible for any radio or television interference caused by unauthorized modifications of this equipment or the substitution or attachment of connecting cables and equipment other than those specified by Honeywell.

The correction is the responsibility of the user.

Use only shielded data cables with this system. This unit has been tested with cables less than 3 meters. Cables greater than 3 meters may not meet class B performance.

Caution: Any changes or modifications made to this equipment not expressly approved by Honeywell may void the FCC authorization to operate this equipment.

Canada

Industry Canada ICES-003

This Class B digital apparatus complies with Canadian ICES-003. Operation is subject to the following conditions:

1. This device may not cause harmful interference.
2. This device must accept any interference received, including interference that may cause undesired operation.

Conformité à la réglementation canadienne

Cet appareil numérique de la Classe B est conforme à la norme NMB-003 du Canada. Son fonctionnement est assujéti aux conditions suivantes :

- Cet appareil ne doit pas causer de brouillage préjudiciable.
- Cet appareil doit pouvoir accepter tout brouillage reçu, y compris le brouillage pouvant causer un fonctionnement indésirable.

Europe

CE The CE marking indicates compliance to 2014/30/EU EMC Directive with Standards EN55032 CLASS B, EN55024, EN61000-3-2, EN61000-3-3. 2011/65/EU ROHS (Recast). In addition, complies to 2014/35/EU Low Voltage Directive, when shipped with recommended power supply.
European contact: Honeywell Productivity Solutions BV Lagelandseweg 70 6545 CG Nijmegen The Netherlands

Honeywell International Inc. shall not be liable for use of our product with equipment (i.e., power supplies, personal computers, etc.) that is not CE marked and does not comply with the Low Voltage Directive.

Use only shielded data cables with this system. This unit has been tested with cables less than 3 meters. Cables greater than 3 meters may not meet class B performance.

Certified to CB Scheme IEC 62368-1, Second Edition.

Refer to www.honeywellaidc.com/environmental for the RoHS / REACH / WEEE information.

CE La marquage CE indique que cet appareil est conforme à la Directive 2014/30/EU et avec les normes EN55032 CLASSE B, EN55024, EN61000-3-2, EN61000-3-3. 2011/65/EU ROHS (Recast). De plus, il est conforme à la Directive sur les basses tensions 2014/35/EU, lorsqu'il est fourni avec le bloc d'alimentation recommandé.

European contact: Honeywell Productivity Solutions BV Lagelandseweg 70 6545 CG Nijmegen The Netherlands

Honeywell ne sera pas tenu responsable de l'utilisation de ses produit avec de l'équipement (c'est-à-dire, blocs d'alimentation, ordinateurs personnels, etc.) qui ne porte pas la marque CE et n'est pas conforme à la Directive sur les basses tensions.

Utiliser uniquement des câbles de données blindés avec ce système. L'appareil a été testé avec des câbles de moins de 3 mètres. Les câbles de longueur supérieure à 3 mètres peuvent ne pas satisfaire à la performance de la classe B.

Certifié CB CEI 62368-1, deuxième édition.

<div></div>	<div></div>
<div></div>	<div></div>
<div></div>	<div></div>
<div></div>	<div></div>
<div></div>	<div></div>
<div></div>	<div></div>
<div></div>	<div></div>
<div></div>	<div></div>
<div></div>	<div></div>
<div></div>	<div></div>
<div></div>	<div></div>

CE 表示设备符合 2014/30/EU EMC 指令和 EN55032 B 类、EN55024、EN61000-3-2、EN61000-3-3。2011/65/EU ROHS (Recast)。的标准要求。此外，在随附建议的电源时，设备还符合 2014/35/EU 低电压指令的要求。

如果通过没有 CE 标记且不符合低电压指令的设备（如，电源、个人计算机等）使用我们的产品，

European contact: Honeywell Productivity Solutions BV Lagelandseweg 70 6545 CG Nijmegen The Netherlands

此系统仅能使用屏蔽数据电缆。此设备是以短于 3 米的电缆进行的测试。长度超过 3 米的电缆可能无法满足 B 级性能。

已通过 CB 方案 IEC 62368-1 第二版的认证。

有关 RoHS / REACH / WEEE 信息，请参阅 www.honeywellaidc.com/environmental。

有毒有害物质名称及含量的标识格式 <p>(Names and Content of Hazardous Substances or Elements)</p>							
部件名称 (Parts Name)	有毒有害物质或元素 <p>(Toxic and Hazardous Substances or Elements)</p>						
	铅 (Pb)	汞 (Hg)	镉 (Cd)	六价铬 (Cr6+)	多溴联苯 (PBB)	多溴二苯醚 (PBDE)	
印刷电路板 (PCB)	o	o	o	o	o	o	
上盖 (Top Cover)	x	o	o	o	o	o	
下盖 (Bottom Cover)	o	o	o	o	o	o	
电源线 (Power Cord)	x	o	o	o	o	o	
本表格依据 SJ/T11364-2014 的规定编制。(The table is created by SJ/T11364-2014 requirement.) <p>o: 表示该有毒有害物质在该部件所有均质材料中的含量均在GB/T26572-2011标准规定的限量要求以下 (Indicates that this toxic or hazardous substance contained in all of the homogeneous materials for this part is below the limit requirement in China’s GB/T26572-2011.) <p>x: 表示该有害物质至少在该部件的某一均质材料中的含量超出 GB/T26572-2011 标准规定的限量要求 (Indicates that this toxic or hazardous substance contained in at least one of the homogeneous materials for this part is above the limit requirement in China’s GB/T26572-2011.)</p></p>							

Reportez-vous à la page www.honeywellaidc.com/environmental pour obtenir des renseignements concernant les directives RoHS/REACH/WEEE.

CE La marquage CE apposée sur ce dispositif atteste qu’il est conforme à la Directive CEM 2014/30/EU et aux normes EN55032 CLASSE B, EN55024, EN61000-3-2, EN61000-3-3. 2011/65/EU ROHS (Recast). En outre, s’il est fourni avec l'alimentation recommandée, ce dispositif est conforme à la Directive « basse tension » 2006/95/CE.

European contact: Honeywell Productivity Solutions BV Lagelandseweg 70 6545 CG Nijmegen The Netherlands

Honeywell ne peut pas être tenu responsable des éventuelles conséquences de l'utilisation de ses produits avec des équipements (modules d'alimentation, ordinateurs personnels, etc.) ne comportant pas la marque CE et non conformes à la Directive sur les basses tensions.

Utilisez uniquement des câbles de données blindés avec ce système. Ce dispositif a été testé avec des câbles de moins de 3 mètres. Il est possible que les câbles de plus de 3 mètres ne permettent pas d'atteindre des performances de classe B.

Certifié selon la norme CEI 62368-1 seconde édition (schéma OC).

Reportez-vous au site www.honeywellaidc.com/environmental pour obtenir les informations sur les directives RoHS/REACH/WEEE.

CE La marcatura CE indica conformità ai sensi della direttiva EMC 2014/30/EU con gli standard EN55032 Classe B, EN55024, EN61000-3-2, EN61000-3-3. 2011/65/EU ROHS (Recast). E conforme inoltre ai sensi della Direttiva bassa tensione 2014/35/EU se spedito con l'alimentatore consigliato.

European contact: Honeywell Productivity Solutions BV Lagelandseweg 70 6545 CG Nijmegen The Netherlands

Honeywell declina ogni responsabilità per l'utilizzo del prodotto con dispositivi (ad esempio alimentatori, personal computer ecc.) non contrassegnati dal marchio CE e non conformi alla Direttiva Bassa Tensione.

Utilizzare solo cavi dati schermati con questo sistema. Questa unità è stata testata con cavi di lunghezza inferiore a 3 metri. I cavi di lunghezza superiore a 3 metri potrebbero non essere conformi alle prestazioni di classe B.

Certificato in base allo Schema CB IEC 62368-1, seconda edizione.

Consultare il sito web www.honeywellaidc.com/environmental per informazioni su RoHS/REACH/RAEE.

<div></div>	<div></div>
<div></div>	<div></div>
<div></div>	<div></div>
<div></div>	<div></div>
<div></div>	<div></div>
<div></div>	<div></div>
<div></div>	<div></div>
<div></div>	<div></div>
<div></div>	<div></div>
<div></div>	<div></div>
<div></div>	<div></div>

CE 標誌代表本裝置符合 2014/30/EU EMC 指令，遵循標準 EN55032 CLASS B、EN55024、EN61000-3-2 和 EN61000-3-3。2011/65/EU ROHS (Recast)。
若本機組附帶建議使用的電源裝置，同時也符合 2014/35/EU 低電壓指令。

若配合未標示 CE 及不符合低電壓指令的設備（即電源供應器、個人電腦等等）使用我們的產品，

European contact: Honeywell Productivity Solutions BV Lagelandseweg 70 6545 CG Nijmegen The Netherlands

此系統只能使用包覆的資料傳輸線。此裝置是使用不到 3 公尺長的電纜進行測試。超過 3 公尺長的電纜可能無法達到 B 級裝置效能。

經過認證符合 CB Scheme IEC 62368-1 標準第二版。

請參閱 www.honeywellaidc.com/environmental 以瞭解 RoHS / REACH / WEEE 資訊。

CE マーキングは、本装置が 2014/30/EU EMC Directive の規格 EN55032 CLASS B、EN55024、EN61000-3-2、EN61000-3-3。2011/65/EU ROHS (Recast)。に準拠していることを示します。また、推奨電源付きで出荷されている場合は、2014/35/EU Low Voltage Directive にも準拠しています。

CE マーキングがなく、Low Voltage Directive に適合しない機器（電源装置、パーソナル コンピュータなど）とともに当社の製品を使用した場合、Honeywell は一切の責任を負いません。

European contact: Honeywell Productivity Solutions BV Lagelandseweg 70 6545 CG Nijmegen The Netherlands

このシステムにはシールド付きデータケーブルのみを使用してください。この装置は長さ 3 m 以下のケーブルでテストされています。3 m 以上のケーブルはクラス B の性能を満たさない場合があります。

CB Scheme IEC 62368-1, Second Edition に認定されています。

RoHS / REACH / WEEE に関する情報については、www.honeywellaidc.com/environmental を参照してください。

CE Die CE-Kennzeichnung wird die Einhaltung der EMV-Richtlinie 2014/30/EU mit den Normen EN55032 Klasse B, EN55024, EN61000-3-2, EN61000-3-3 angezeigt. 2011/65/EU ROHS (Recast). Ferner entspricht dieses Gerät der Niederspannungsrichtlinie 2006/95/EG, wenn es mit dem empfohlenen Netzteil geliefert wird.

European contact: Honeywell Productivity Solutions BV Lagelandseweg 70 6545 CG Nijmegen The Netherlands

Honeywell haftet nicht für die Verwendung seiner Produkte mit Komponenten (z. B. Stromversorgungen, PCs usw.), die nicht mit dem CE-Zeichen gekennzeichnet sind und die nicht den Vorschriften der Niederspannungsrichtlinie entsprechen.

Für dieses System nur abgeschirmte Datenkabel verwenden. Dieses System wurde mit Kabeln unter 3 Metern Länge geprüft. Kabel mit einer Länge von über 3 Metern erfüllen möglicherweise nicht die Richtlinien der Klasse B.

CB-zertifiziert gemäß IEC 60950, Second Edition.

Unter www.honeywellaidc.com/environmental finden Sie Informationen über RoHS/REACH/WEEE.

CE El mercado CE indica que cumple con la Directiva 2014/30/EU EMC y los estándares EN55032 Clase B, EN55024, EN61000-3-2, EN61000-3-3. 2011/65/EU ROHS (Recast). Además, cumple con la Directiva 2014/35/EU sobre el material eléctrico destinado a utilizarse con determinados límites de tensión, cuando se envía con una fuente de alimentación recomendada.

European contact: Honeywell Productivity Solutions BV Lagelandseweg 70 6545 CG Nijmegen The Netherlands

Honeywell no será responsable del uso de sus productos con equipos (p. ej., fuentes de alimentación, ordenadores personales, etc.) que no presenten la marca CE y no cumplan con la Directiva sobre el material eléctrico destinado a utilizarse con determinados límites de tensión.

Utilice sólo cables de datos blindados con este sistema. Esta unidad se ha probado con cables de longitud inferior a 3 metros. Cables superiores a 3 metros quizá no satisfagan los requisitos de rendimiento de la clase B.

Se ha certificado que cumple el esquema CB IEC 62368-1, segunda edición.

Consulte www.honeywellaidc.com/environmental para obtener información sobre RoHS/REACH/WEEE.

<div></div>	<div></div>
<div></div>	<div></div>
<div></div>	<div></div>
<div></div>	<div></div>
<div></div>	<div></div>
<div></div>	<div></div>
<div></div>	<div></div>
<div></div>	<div></div>
<div></div>	<div></div>
<div></div>	<div></div>
<div></div>	<div></div>

CE CE 표시는 2014/30/EU EMC Directive 의 표준 EN55032 CLASS B, EN55024, EN61000-3-2, EN61000-3-3. 2011/65/EU ROHS (Recast). 을 준수함을 의미합니다. 또한, 권장되는 전원 공급장치와 함께 제공되는 경우에는 2014/35/EU Low Voltage Directive 를 준수함을 의미합니다 .

Honeywell 는 Low Voltage Directive 의 조항을 준수하지 않고 CE 기호를 획득하지 않은 장비 (예 : 전원 공급 장치, PC 등) 와 함께 당사 제품을 사용함으로써 발생하는 어떠한 문제에도 책임을 지지 않습니다 .

European contact: Honeywell Productivity Solutions BV Lagelandseweg 70 6545 CG Nijmegen The Netherlands

이 시스템에는 차폐된 데이터 케이블만 사용하십시오 . 본 장치는 3 미터 미만의 케이블 로 테스트를 받았습니다 . 3 미터를 초과하는 케이블을 사용하면 Class B 성능을 만족시키지 못할 수 있습니다 .

CB Scheme IEC 62368-1, Second Edition 인증을 받았습니다 .

RoHS / REACH / WEEE 정보는 www.honeywellaidc.com/environmental 에서 참조하십시오 .

CE Маркировка CE означает соответствие Директиве по электромагнитной совместимости 2014/30/EU со стандартами EN55032 CLASS B, EN55024, EN61000-3-2, EN61000-3-3. 2011/65/EU ROHS (Recast).Кроме того, соответствие Директиве по низкому напряжению 2014/35/EU при отправке с рекомендуемым источником питания.

European contact: Honeywell Productivity Solutions BV Lagelandseweg 70 6545 CG Nijmegen The Netherlands

Компания Honeywell не несет ответственность за использование нашего товара с оборудованием (например, источниками питания, персональными компьютерами) без маркировки CE, которое не соответствует Директиве по низкому напряжению.

Используйте с этой системой только экранированные кабели передачи данных. Это устройство прошло испытания с использованием кабелей длиной менее 3 метров. Рабочие характеристики кабелей длиной свыше 3 м могут не соответствовать классу B.

Сертификация согласно схеме CB МЭК 62368-1, издание второе.

Информация о соответствии требованиям RoHS / REACH / WEEE приведена на сайте www.honeywellaidc.com/environmental.

United Kingdom Contact:

Honeywell Scanning and Mobility
Honeywell House, Skimped Hill Lane
Bracknell, Berkshire, RG12 1EB
Phone: +44 (0)1344921052

CE El mercado CE indica que cumple con la Directiva 2014/30/EU EMC con los Estándares EN55032 CLASE B, EN55024, EN61000-3-2 y EN61000-3-3. 2011/65/EU ROHS (Recast). Además, cumple con la Directiva 2014/35/EU sobre baja tensión cuando se envía con la fuente de alimentación recomendada.

European contact: Honeywell Productivity Solutions BV Lagelandseweg 70 6545 CG Nijmegen The Netherlands

Honeywell no asumirá responsabilidad por el uso de sus productos con equipos (p. ej., fuentes de alimentación, computadoras personales, etc.) que no presenten la marca CE y no cumplan con la Directiva sobre baja tensión.

Use únicamente cables protegidos para datos con este sistema. Esta unidad ha sido evaluada con cables de menos de 3 metros. Es posible que los cables de más de 3 metros no cumplan con el desempeño de clase B.

Se ha certificado que cumple con el esquema CB IEC 62368-1, segunda edición.

Consulte la información RoHS/REACH/WEEE en www.honeywellaidc.com/environmental.

CE A marcação CE indica conformidade com a Diretiva EMC 2014/30/EU, com os Padrões EN55032 CLASSE B, EN55024, EN61000-3-2 e EN61000-3-3. Além disso, indica conformidade com a Diretiva para baixa tensão 2014/35/EU, quando o dispositivo é enviado com a fonte de alimentação recomendada.

European contact: Honeywell Productivity Solutions BV Lagandseweg 70 6545 CG Nijmegen The Netherlands

Honeywell não se responsabiliza pelo uso de nossos produtos com equipamentos (fontes de alimentação, computadores pessoais, etc.) que não estejam marcados com CE e em conformidade com a Diretriz de Baixa Voltagem.

Use somente cabos de dados blindados com este sistema. Esta unidade foi testada com cabos com menos de 3 metros. Cabos com mais de 3 metros não atendem o desempenho de classe B.

Certificação CB Scheme IEC 62368-1, Segunda edição.

Consulte a página www.honeywellaidc.com/environmental para obter informações sobre as normas RoHS/REACH/WEEE.

Support

To search our knowledge base for a solution or log into the Technical Support portal and report a problem, go to **www.hsmcontactsupport.com**.

User Documentation

<div></div>	<div></div>
<div></div>	<div></div>
<div></div>	<div></div>
<div></div>	<div></div>
<div></div>	<div></div>
<div></div>	<div></div>
<div></div>	<div></div>
<div></div>	<div></div>
<div></div>	<div></div>
<div></div>	<div></div>
<div></div>	<div></div>

Limited Warranty

For warranty information, go to **www.honeywellaidc.com** and click Resources > Warranty.

Patents

For patent information, see **www.hsmpats.com**.

Trademarks

RAM and RAM Mount are trademarks and/or registered trademarks of National Products Inc.

Disclaimer

Honeywell International Inc. (“HII”) reserves the right to make changes in specifications and other information contained in this document without prior notice, and the reader should in all cases consult HII to determine whether any such changes have been made. The information in this publication does not represent a commitment on the part of HII.

HII shall not be liable for technical or editorial errors or omissions contained herein; nor for incidental or consequential damages resulting from the furnishing, performance, or use of this material. HII disclaims all responsibility for the selection and use of software and/or hardware to achieve intended results.

This document contains proprietary information that is protected by copyright. All rights are reserved. No part of this document may be photocopied, reproduced, or translated into another language without the prior written consent of HII.

Copyright © 2015-2021 Honeywell International Inc. All rights reserved.